



ISK-B300

Installation Manual & User Guide

Smart All-Inclusive
Access Control Unit

ISK-B300 Installation Manual and User Guide

| | |
|---|----|
| Introduction | 3 |
| Specifications | 3 |
| Features | 4 |
| Template for ISK-B300 Smart Keypad | 5 |
| Dimensions | 7 |
| Installation Instructions | 8 |
| Colored Wire and Function Chart | 13 |
| Device Category 1: Description and Wiring Diagram | 14 |
| Device Category 2: Description and Wiring Diagram | 18 |
| Operational Details | 21 |
| Basic Programming | 22 |
| Simplified Local Programming | 23 |
| Smart Initialization for DPS and DBM Sensors | 27 |
| Wiegand Reader Mode | 29 |
| Downloading and Setting Up the INOX Smart App | 30 |
| Adding a Property to the App | 34 |
| Adding a Door to the App | 37 |
| Pairing an ISK Access Control Keypad with the INOX Smart App | 40 |
| Pairing an ISK Access Control Keypad with a Wi-Fi / POE Gateway | 45 |

Introduction

The ISK-B300 is a Smart All-Inclusive Access Control Device that supports multiple credential technologies including high-frequency RFIDs, secured cloud-generated passcodes and mobile user credentials.

- Integrates with cloud-connected wireless communication technology
- Provides intuitive and convenient smartphone access management
- Combines all functionalities of a controller, reader, monitor and user management system

Specifications

- Type: Back Lit Digital Touchscreen
- Style: Mullion
- Frequency: 13.56MHz / 125KHz
- Input Voltage: 12/24 V DC
- RF Output: 13.56MHz or 125KHz (reader) – 26-Bit Wiegand
- Read Interface: EM / MIFARE
- Read Range: ~3/4" – 2-1/2"
- Working Current: < 80mA (12v) ~ < 40mA (24v)
- Standby Current: < 30mA (12v) ~ < 20mA (24v)
- Passcode/PIN Length: 4 – 8 digits
- User Capacity: 2000: Mobile Credential 1000, RF/Passcode 1000
- Working Humidity: 0% to 98%
- Working Temperature: -20°F to 140°F
- Water Resistant: IP66

Features

- All-inclusive device: Reader, Controller, Keypad, and Monitor
- Multi-credential support: Passcodes, RFID FOB/Card/Wristband, and Smart Phone
- Remote Access and Management via Wi-Fi and Low Energy Bluetooth
- Cloud-based APP with a simple yet robust hierarchy of user roles
- Customizable permissions and levels for managing e-keys, users, and devices
- Passage Mode: Enjoy free access during scheduled periods
- Privacy Mode: Keep privacy and security when needed
- Real-time Audit trail and backup email
- Door position sensor for monitoring open/closed status
- Latchbolt or Deadbolt Monitoring Sensor for monitoring locking status
- Modern, water-resistant indoor/outdoor touchscreen keypad with IP66 rating

Template for ISK-B300 Smart Keypad

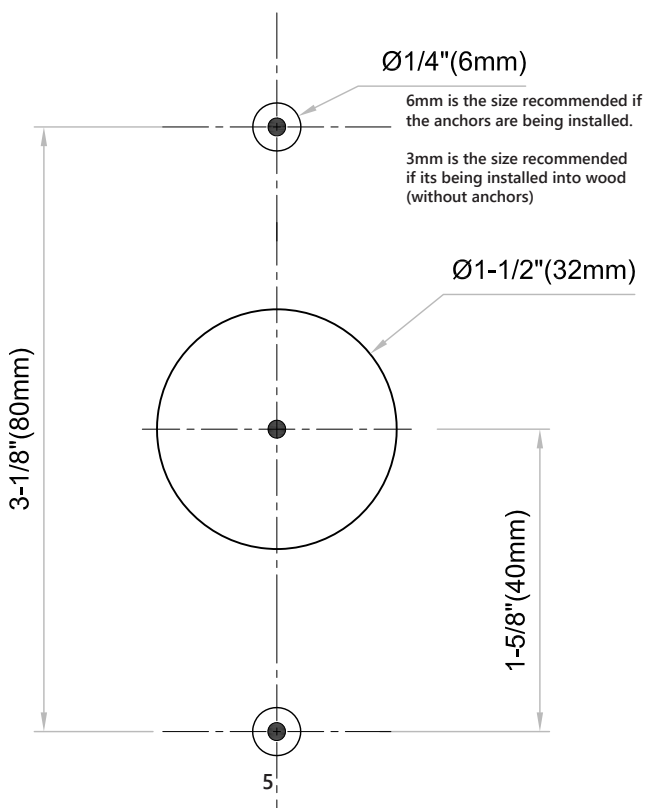

**This page intentionally
left blank for removal with
ISK-B300 Installation Template**

Dimensions

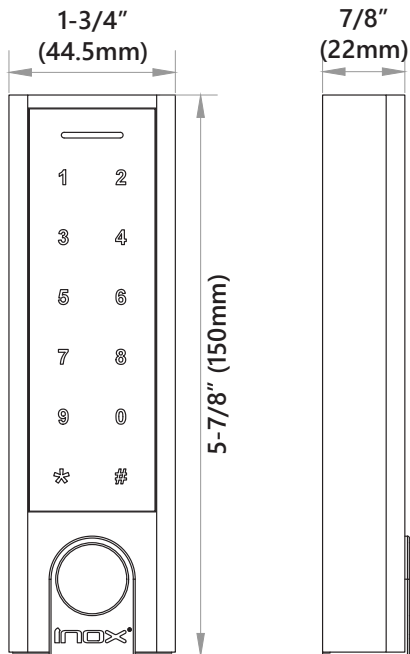

STEP 1

Installation Instructions



Prep the mounting location by drilling holes as shown in the template.

STEP 2

Installation Instructions

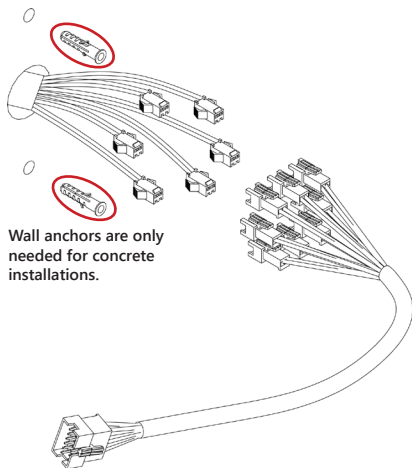

Wall anchors are only needed for concrete installations.

Install anchors. Pull Molex wires through the center hole and connect according to wiring diagram. Keep any unused wires isolated and protected.

STEP 3

Installation Instructions

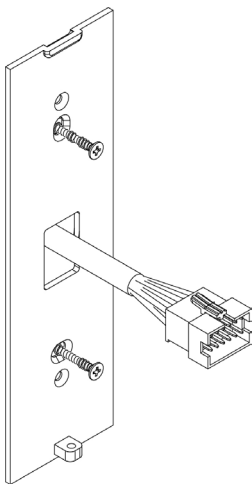

Install screws to mount the sub-plate.

STEP 4

Installation Instructions

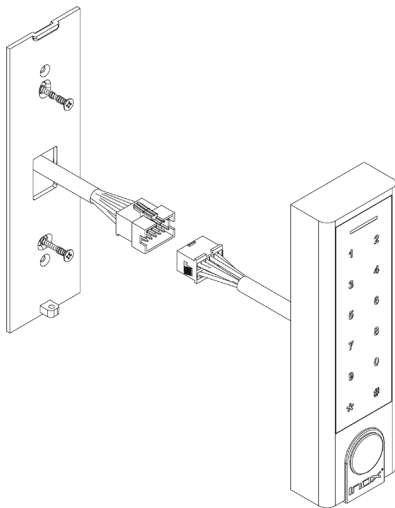

Connect the Molex from the ISK-B300 with the Molex from the locking device.

STEP 5

Installation Instructions

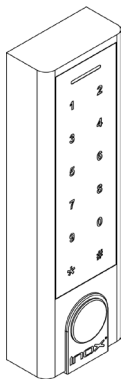

Use the tool provided to fix the smart controller to the sub-plate by installing the tamper resistant screw into the bottom of the unit.

Colored Wire and Function Chart

| Wire Color | Function | Notes |
|---|--------------|---|
| Basic Standalone Wiring | | |
| Red | DC+ | 12-24VDC Power Input |
| Black | GND | Negative Pole of DC Power Input |
| Blue | Relay NO | Normally Open Relay Output (install diode provided) |
| White | Relay Common | Common Connection for Relay Output |
| Brown | Relay NC | Normally Closed Relay Output (install diode provided) |
| Orange | REX/Open | Request to Exit (REX) Input |
| Pass-Through Wiring (Wiegand Reader or Controller) | | |
| Green/Black | Data 0 | Wiegand Output (Pass-Through) Data 0 |
| White/Black | Data 1 | Wiegand Output (Pass-Through) Data 1 |
| Advanced Input and Output Features | | |
| Grey | Alarm Output | Negative Contact for Alarm |
| Yellow | DPS Input | Door/Gate Contact Input (Normally Closed) |
| Green | DBM Input | Input Status of Deadbolt/Latch Bolt |

Device Category 1: Description and Wiring Diagram

The ISK-B300 Smart Access Controller can be connected to Electromagnetic locking devices as EL (Fail Safe) or EU (Fail Secure). These include but are not limited to:

- Electrified Mortise Locks
- Electrified Cylindrical Locks
- Electric Strikes
- Electrified Exit Trims
- Maglocks

1. Connect Power to the devices and power supply with the correct voltage.
2. Connect the Common and Normally Open (NO) or Normally Closed (NC) with the devices.
3. For Electrically-Unlocked (EU)/Fail Secure devices, connect NO and Common lines.
4. For Electrically-Locked (EL)/Fail Safe devices, connect NC and Common lines.

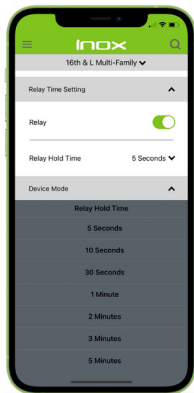

The default timing on the closing circuits is 5 seconds. In the Smart Mode, this timing is adjustable from 5 seconds to 5 minutes using the Smart APP in Device Settings.

Category 1 Wiring

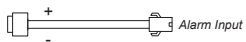
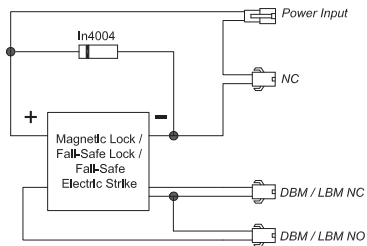
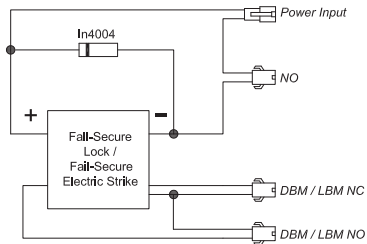

Category 1 Wiring (Cont.)

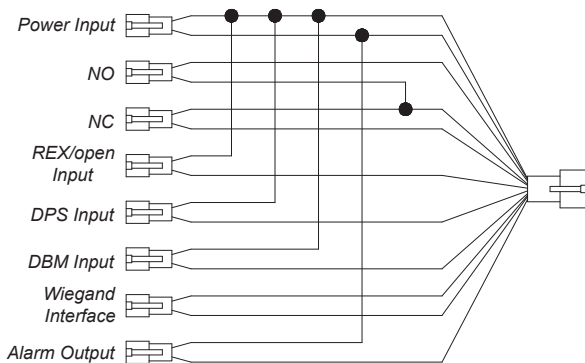

Category 1 Wiring (Cont.)

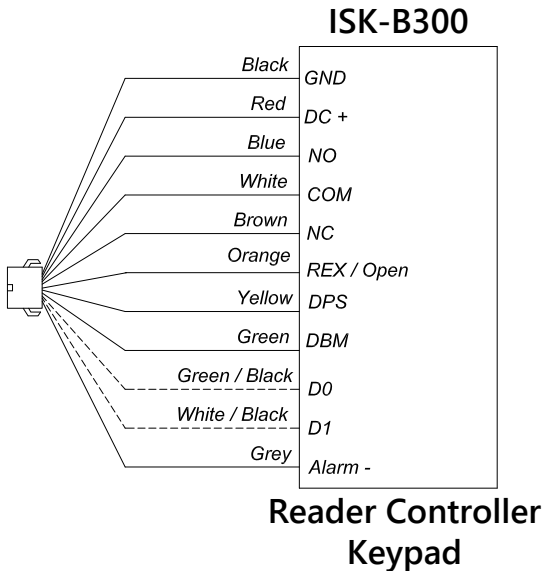

Device Category 2: Description and Wiring Diagram

Motor-driven Mortise Lock, i.e. INOX PD9700

Category 2 Wiring

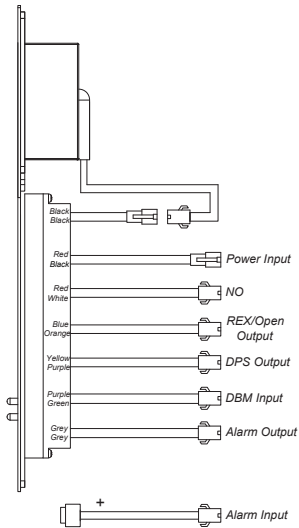

Category 2 Wiring (Cont.)

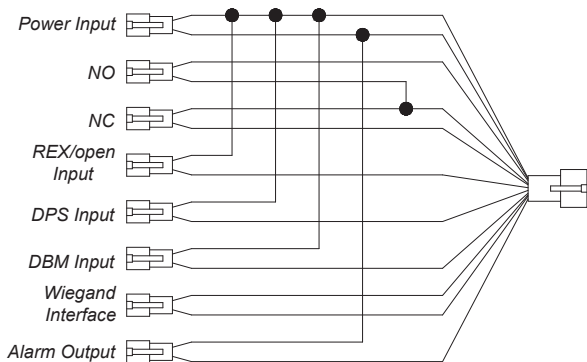

Category 2 Wiring (Cont.)

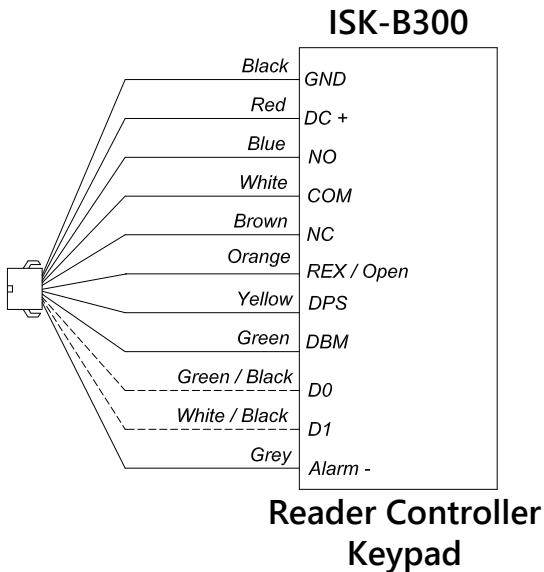

Operational Details

| | |
|------------------------------|---|
| Operating Voltage | 12~24VDC |
| Working Current | ≤150mA |
| Idle Current | ≤60mA |
| Proximity Card Reader | EM / EM + Mifare |
| Radio Technology | 125KHz / 125KHz + 13.56MHz |
| Read Range | 1" Maximum |
| PIN Length | 4-8 Digits |
| Wiring Connections | Relay Output, Exit Button, Alarm, Door Contact, Wiegand Input, Wiegand Output |
| Relay | One (NO, NC, Common) |
| Adjustable Relay Output Time | 0-99 Seconds (5 Seconds Default) |
| Lock Output Load | 2 Amp Maximum |
| Wiegand Interface | EM Card: Wiegand 26~44 bits input & output Mifare Card: Wiegand 26~44 bits, 56 bits, 58 bits input and output (Factory Default: Wiegand 26 bits for EM card, Wiegand 34 bits for Mifare card) |
| Environment | Meets IP66 |
| Operating Temperature | (-40°F~140°F) |
| Operating Humidity | 0%RH~98%RH |
| Physical | Zinc-Alloy |
| Color | Black, Painted Aluminum |
| Dimensions | 5-7/8"L x 1-3/4"W x 7/8"D |
| Unit Weight | 330g |
| Shipping Weight | 405g |

Basic Programming

Sound and Light Indication

| Operation Status | LED | Buzzer |
|--------------------|--------------------|--------------------|
| Standby | Solid red light | -- |
| Enter Program Mode | Flashing red light | One beep |
| In Program Mode | Solid orange light | One beep |
| Operation error | -- | Three beeps |
| Exit Program Mode | Flashing red light | One beep |
| Unlocked | Solid green light | One beep |
| Alarm | Flashing red light | Continuous beeping |

Basic Configuration

| Programming Step | Keystroke Combination |
|--------------------|---|
| Enter Program Mode | * (Master Code) # (Factory default is 123456) |
| Exit Program Mode | * |

Set Master Code¹ (Complete this step for full App functionality)

| Programming Step | Keystroke Combination |
|-----------------------|---|
| 1. Enter Program Mode | * (Master Code) # |
| 2. Update Master Code | 0 (New Master Code) # (Repeat New Master Code) # (Master Code is any 6 digits) |
| 3. Exit Program Mode | * |

¹ Adding passcodes through the INOX Smart App will not be available until Master Code is changed from Factory Default.

Simplified Local Programming

Definitions:

Programming Locally: Credentials are saved & stored locally at the device level. User ID's and PIN Numbers should be documented as they cannot be accessed through the INOX Smart App.

Programming Through App: Credentials are saved & securely stored on the cloud. User's information is accessible through the INOX Smart App and actions will be recorded on the Audit Log within the App.

| Simplified Instruction | |
|--|---|
| Programming Step | Keystroke Combination |
| Enter Program Mode | * (Master Code) # (Factory default is 123456) - then perform additional operations below |
| Select a Specific ID (allows the device to define a specific User ID to associate the PIN to) | 1 (UserID) # (PIN) # The UserID is 0-999 The PIN is any 4-6 digits except 8888 which is reserved |
| Exit Program Mode | * |

| Delete Users | |
|----------------------------|--|
| Programming Step | Keystroke Combination |
| Enter Program Mode | * (Master Code) # (Factory default is 123456) - then perform additional operations below |
| Delete User - By ID Number | 2 (UserID) # |
| Delete All Users | 2 (Master Code) # |
| Exit Program Mode | * |

Set Access Mode

For multi-user Access Mode, each entry cannot exceed five seconds, or the device will exit to Standby Mode automatically.

| Programming Step | Keystroke Combination |
|--|--|
| 1. Enter Program Mode | * (Master Code) # |
| 2. Card Access OR 2. PIN Access OR 2. Card + PIN Access OR 2. Card or PIN Access | 4 0 # 4 1 # 4 2 # 4 3 # |
| 3. Exit Program Mode | * |

Set the Working Mode

The device has 3 working modes to choose from: Standalone Mode, Smart Mode, and Wiegand Reader Mode (factory default is Standalone Mode / Smart Mode).

| Programming Step | Keystroke Combination |
|--|--|
| 1. Enter Program Mode | * (Master Code) # |
| 2. Standalone / Smart Mode OR 2. Wiegand Reader Mode | 7 7 # (Factory Default) 7 8 # |
| 3. Exit Program Mode | * |

Set Strike-out Alarm

The strike-out alarm will engage after 10 failed entry attempts (factory setting is OFF). It can be set to deny access for 10 minutes after engaging, or disengage only after entering a valid card/PIN or Master Code / card.

The Strike-Out Alarm will engage after 10 failed entry attempts (Factory Default Setting is OFF).

Once turned on, if Strike-Out alarm is activated, access will be denied for 10 minutes. This is bypassed by entering valid Card/PIN or Master PIN. The duration of the alarm can be adjusted between 1-3 minutes; the factory default is 1 minute.

| Programming Step | Keystroke Combination |
|--|--|
| 1. Enter Program Mode | * (Master Code) # |
| 2. Strike-Out OFF OR 2. Strike-Out ON OR 2. Strike-Out ON Set Alarm Time | 6 0 # 6 1 # 6 2 # (Factory Default is 1 minute) 5 0 # Alarm will not ring 5 1 # Alarm will ring for 1 minute 5 2 # Alarm will ring for 2 minutes 5 3 # Alarm will ring for 3 minutes |
| 3. Exit Program Mode | * |

Unpair the Device with the INOX Smart App

Once the ISK-B300 is paired with an opening on the INOX Smart App, it cannot be paired with a different opening unless it is unpaired first.

To unpair on the local device:

* (Master Code) # - 9 - (Master Code) #

To unpair on INOX Smart App:

Delete the device from the Device Information Screen

NOTE: After unpairing the Device with the INOX Smart App, the user information will be removed from the App.

Reset ISK-B300 to Factory Default

- Connect REX wire (orange) and black negative terminal
- Power off
- Power on
- There will be two audible beeps
- Wait 8 seconds for another audible beep and green light flash
- Then the Master Code is reset to factory default (123456)

How to Unlock the Door

| | |
|-----------|-----------|
| Card User | Read Card |
| PIN User | Input PIN |

Smart Initialization for DPS and DBM Sensors

DPS may be added to Electro Magnetic Locking Devices (Category 1)
DPS & DBM may be added to Motor Driven Locking Devices
(Category 2)

Open Door Detection (DPS - Door Position Sensor)

When the lock is used with an optional magnetic contact or built-in magnetic contact and the door is opened normally and remains open for more than one minute, the inside buzzer will sound automatically as a reminder to close the door. The buzzer will stop if the door is closed, or if valid credentials are used. Otherwise the buzzer will continue to sound for the programmed alarm time.

DBM - Deadbolt Monitoring Detection

When DBM Detection is enabled for a lock with a latchbolt or deadbolt, if the door is not closed properly there is potential for the latchbolt or deadbolt to not make contact with the DBM paddle in the Electric Strike. When this occurs, the INOX Smart App will detect that the latchbolt or deadbolt is not engaged inside the strike. The App will then send a "locking failed" notification, and/or the door will appear unlocked on the App screen.

Smart Initialization for DPS and DBM Sensors (Cont.)

| Programming Step | Keystroke Combination |
|---|---|
| 1. Enter Program Mode | * (Master Code) # |
| 2. Disable DPS Detection OR 2. Enable DPS Detection | 6 3 # (factory default) 6 4 # |
| 2. Disable DBM Detection OR 2. Enable DBM Detection | 6 5 # (factory default) 6 6 # |
| 3. Set Alarm Time | 5 (0-3) # (factory default is 1 minute) 5 0 # = 0 minutes (no alarm sound) 5 1 # = 1 minute 5 2 # = 2 minutes 5 3 # = 3 minutes |
| 4. Exit Program Mode | * |

Wiegand Reader Mode

The device can work as a Standard Wiegand Reader connected to a third-party controller (7 8 #).

Connection Diagram

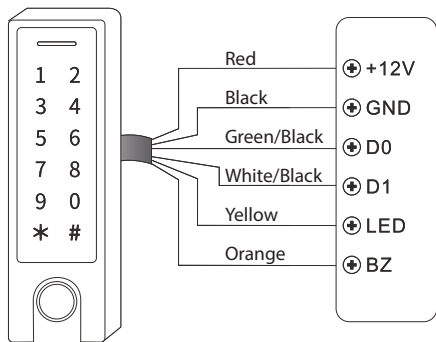

Notes:

When set to Wiegand Reader Mode, most settings in Controller Mode are inactive, and the Yellow and Orange wires are redefined as below:

- Yellow Wire: Green LED light control
- Orange Wire: Buzzer control

If you need to connect the Yellow / Orange wires:

When the input voltage for LED is low, the LED will turn green. When the input voltage for the Buzzer is low, it will sound.

InoxSmart

Downloading and Setting Up the INOX Smart App

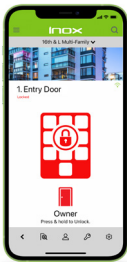

Use the QR code below for additional support, or visit

InoxSmart.com



1

Downloading and Setting Up the INOX Smart App

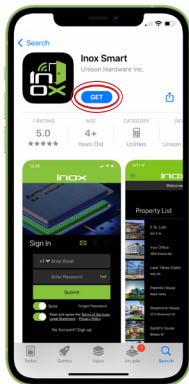

From the Apple or Google Play Store, download the app "INOX Smart."



2 Downloading and Setting Up the INOX Smart App



Open the App on your Smart device.

3 Downloading and Setting Up the INOX Smart App

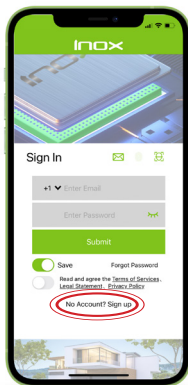

At the first screen, tap "No Account? Sign up."

4

Downloading and Setting Up the INOX Smart App

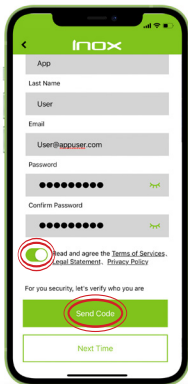

Fill in Name, Email, and Password fields, and accept the Terms of Service, Legal Statement and Privacy Policy by activating the toggle.

Selecting the green “Send Code” button will send a Registration Verification code to your email address.

5

Downloading and Setting Up the INOX Smart App

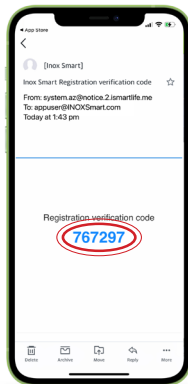

Locate the email that contains your registration verification code.

6 Downloading and Setting Up the INOX Smart App

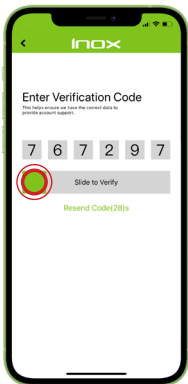

Enter this code on the next screen and slide the green button to the right to verify.

7 Downloading and Setting Up the INOX Smart App

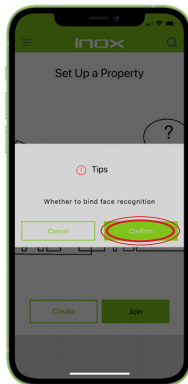

If enabled, your Smart device may ask if you want to use Face ID or Touch ID as credentials to verify App access.

Adding a Property to the App



Use the QR code below for additional support, or visit

InoxSmart.com



1

Adding a Property to the App

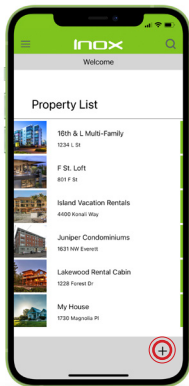

These instructions cover the procedures for creating a new property in the InoX Smart App. For instructions on how to join an existing property, see the FAQs at InoxSmart.com.

To add a new property, tap the “+” icon in the lower right corner of the Property screen.

2

Adding a Property to the App



To create a new property, select the Create button at the bottom of the Set Up a Property screen.

3

Adding a Property to the App

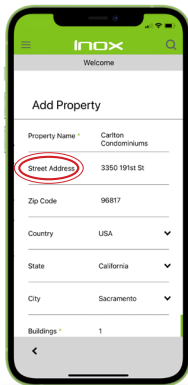

Fill in the property information, including address and number of buildings. To edit the number of buildings, slide the Buildings option to the left.

4

Adding a Property to the App

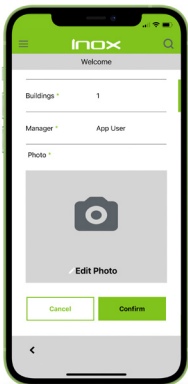

The INOX Smart App requires a photo for each property. Tap on Edit Photo to access the photo screen.

5

Adding a Property to the App

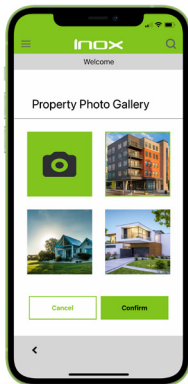

Tap the Camera icon to access your camera or photo gallery.

You may also choose a stock photo provided by the App.

Tap Confirm.

Adding a Door to the App

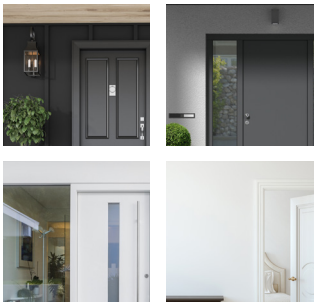

Use the QR code below for additional support, or visit

InoxSmart.com



1

Adding a Door to the App

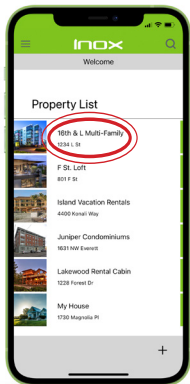

Doors are added to specific properties. Tap on the property to select.

2

Adding a Door to the App

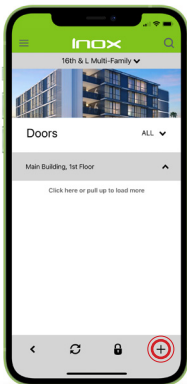

To add a door, tap the “+” icon in the lower right corner of the Doors screen.

3

Adding a Door to the App

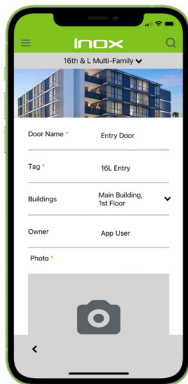

Fill in identifying information about the door. The INOX Smart App requires a photo for each door. Tap on the Edit Photo box to access the photo screen.

4

Adding a Door to the App

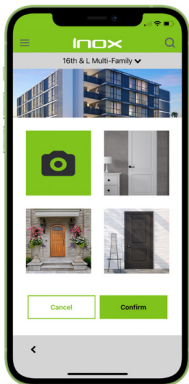

Tap the Camera icon to access your camera or photo gallery. You may also choose a stock photo provided by the App.

Tap Confirm.

5

Adding a Door to the App

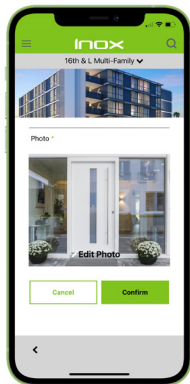

The photo will be added to the door information.

Tap Confirm to add the door.



Pairing an ISK Access Control Keypad with the INOX Smart App

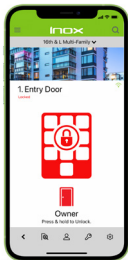
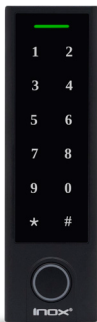

Use the QR code below for additional support, or visit

[InoxSmart.com](https://www.inoxsmart.com)



1 Pairing an ISK Access Control Keypad with the INOX Smart App

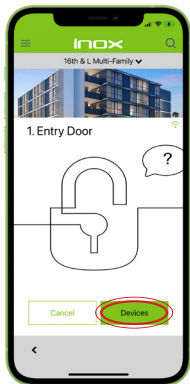

From the Lock Screen, tap the Devices button in the bottom right corner of the screen.

2 Pairing an ISK Access Control Keypad with the INOX Smart App

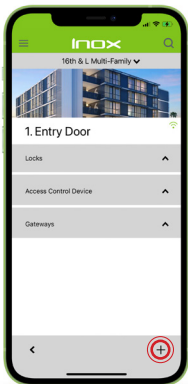

To add a device, tap the "+" icon in the bottom right corner of the screen.

3 Pairing an ISK Access Control Keypad with the INOX Smart App

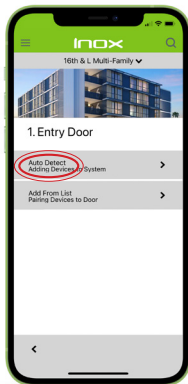

Choose "Auto Detect" to search for available locking devices.

4 Pairing an ISK Access Control Keypad with the INOX Smart App

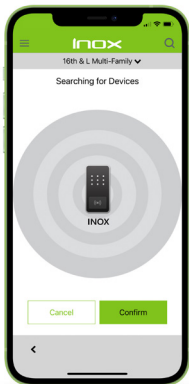

The screen will automatically populate with all available access control and locking devices that are within Bluetooth range of the smartphone or gateway.

If no devices are available, this screen will remain blank.

5 Pairing an ISK Access Control Keypad with the INOX Smart App

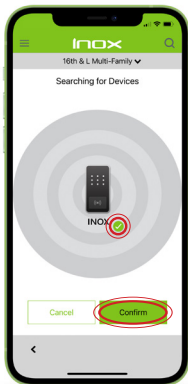

Tap the device that you would like to pair with the App. A green check mark will appear next to your selection.

Tap Confirm.

6 Pairing an ISK Access Control Keypad with the INOX Smart App

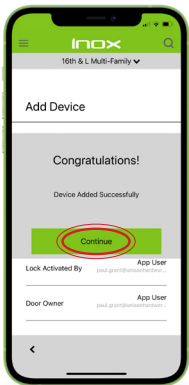

When the device is paired with the App, the Congratulations screen will be shown.

Tap Continue.

7 Pairing an ISK Access Control Keypad with the INOX Smart App

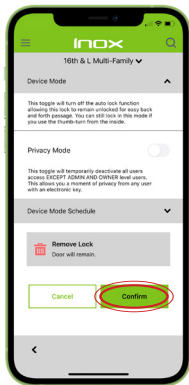

On the Add Device screen, rename the device by tapping on the name.

Edit any other relevant information, including Auto Lock, Privacy Mode, or Passage Mode settings.

Scroll to the bottom of the screen and tap Confirm.

8 Pairing an ISK Access Control Keypad with the INOX Smart App

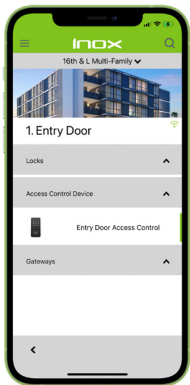

The Access Control unit will appear in the list of devices that are paired with the App for this door.

9 Pairing an ISK Access Control Keypad with the INOX Smart App

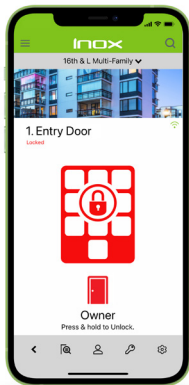

To control the lock, return to the lock screen. Tap and hold on the central lock icon for 2 to 3 seconds.



Pairing an ISK Access Control Keypad with a Wi-Fi / POE Gateway



Use the QR code below for
additional support, or visit
InoxSmart.com



1 Pairing an ISK Access Control Keypad with a Wi-Fi / POE Gateway

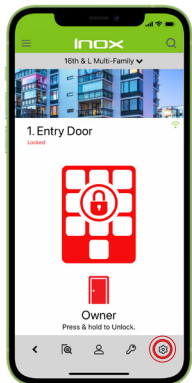

From the Lock Screen, tap the Settings
icon in the bottom right corner
of the screen.

2 Pairing an ISK Access Control Keypad with a Wi-Fi / POE Gateway

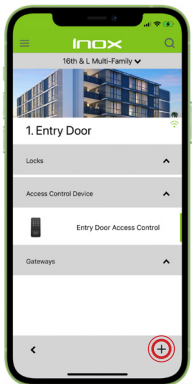

To add a gateway, tap the “+” icon in the bottom right corner of the screen.

3 Pairing an ISK Access Control Keypad with a Wi-Fi / POE Gateway

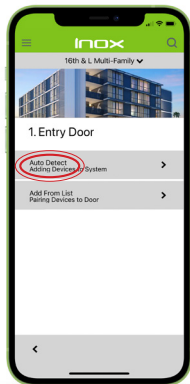

Choose “Auto Detect” to search for available devices.

4 Pairing an ISK Access Control Keypad with a Wi-Fi / POE Gateway



The screen will automatically populate with all available devices that are within Bluetooth range.

If no devices are available, this screen will remain blank.

5 Pairing an ISK Access Control Keypad with a Wi-Fi / POE Gateway

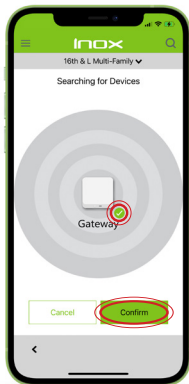

Tap the gateway that you would like to pair with the access control device. A green check mark will appear next to your selection.

Tap Confirm.

6a Pairing an ISK Access Control Keypad with a Wi-Fi / POE Gateway



Connecting by Wi-Fi:

Select a 2.4Ghz network. Enter the network password and tap Confirm.

No password is required for a hardwired POE gateway.

Note: the gateways are not compatible with 5Ghz networks.

6b Pairing an ISK Access Control Keypad with a Wi-Fi / POE Gateway



If the password field is left blank when connecting to an iOS device, an additional screen is shown as a reminder that connecting by Wi-Fi requires a password.

Tap Cancel to go back and enter a Wi-Fi password, or Confirm if connecting to a POE gateway.

7 Pairing an ISK Access Control Keypad with a Wi-Fi / POE Gateway

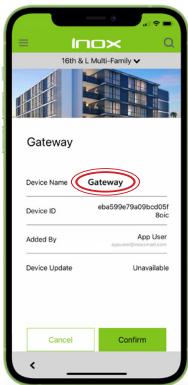

Enter a name for the gateway in the Device Name field. If there is a firmware update available, the Device Update field will show "Available." Tap the word "Available" to update the firmware.

Tap Confirm to complete the pairing process.

8 Pairing an ISK Access Control Keypad with a Wi-Fi / POE Gateway

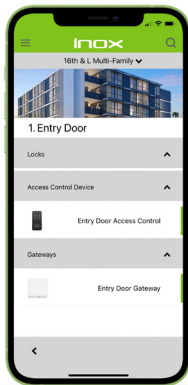

The gateway will appear in the list of devices that are paired with the App for this door.

ISK-B300 Keypad Reader / Controller



ISK-B300 Keypad Reader / Controller

- Connects directly to any hardwired electrified locking device
- Fully integrated with the INOX Smart App



- Designed for access management at entries, exits, gates, pools, and many other environments
- Communicates in near proximity with Bluetooth Low Energy and remotely through a Wi-Fi gateway
- Modern touchscreen keypad, IP66 waterproof



InoXSmart.com

INOX® 6 Wayne Court, Sacramento, CA 95829, USA
Tel: +1 916.388.1888 Fax: +1 916.388.8322 Email: sales@unisonhardware.com